

## Radial Saw



## Detail Sheets

A radial arm or cut-off saw has a circular blade that is pulled across the stock to cut it. The machine usually consists of a motor suspended by a yoke that rolls or slides, on a horizontal arm or beam, above the work table. The saw revolves at approximately 3600 RPM. Although the most common use of this type of saw is for cut-off or cross-cutting purposes, the cutting head can be rotated 90 degrees in either direction to assume a rip position with the saw blade parallel to the fence. Practically all these saws also have a means of tilting the head so that bevel cuts can be made. The saw can be used for compound bevel/mitter cuts, for dadoing, drilling, rabbetting, shaping, grinding and buffing, and sanding.

### Terms

**Cross cutting:** In practically all cases, saws of this type are pulled across the cutting area by means of a handle located to one side of the saw blade, rather than in line with the saw blade. The operator should stand on the handle side, pull the cutting head with the hand nearest the handle, and maneuver the lumber with the other hand. This position keeps the body out of line with the saw blade, and, at the same time, makes it unnecessary for an operator's hand to be near the cutting zone of the saw blade.

**Ripping:** When ripping, the saw head is rotated 90 degrees to a position parallel to the fence and is clamped in position. The saw blade is then lowered until it will cut through to the stock. Before ripping, the nose of the guard or dropdown guard, and the spreader/antikickback devices are positioned. The stock is fed against the revolving blade from the nose of the guard, the side at which the saw blade rotates upward toward the operator. For "in-rip" the material is fed from right to left; for "out-rip" the material is fed from left to right.

**Operator involvement:** The operator must position the stock, hold it stationary, and then grasp the sawing mechanism and pull it across the stock. After the cut is complete, the blade must return to its original position behind the stock and then the stock is repositioned for the next cut.

**Hazards:** Amputations, lacerations or fractures from contact with saw blade. The blade is not only very sharp, but it revolves so fast as to appear as a blur. If contact were made, even for a millisecond, it would cause severe injury. Impact injuries from kickbacks during ripping operation where stock is thrown back at operator due to pinching/binding blade. Eye injuries due to flying wood chips.

**Machines:** On applications where injury to the operator might result if motors were to restart after power failures, prevent them from automatically restarting upon restoration of power. Example of a device that prevents restarting: magnetic motor starter. 1910.213(b)(3).

Provide a clearly marked start/stop control so operator can cut off the power supply to the machine without leaving his normal operating position. Position controls so that it is not necessary for the operator to reach over, under or past unguarded moving parts, work pieces or cutters that can cause injury. 1910.213(b)(1) and (b)(4).

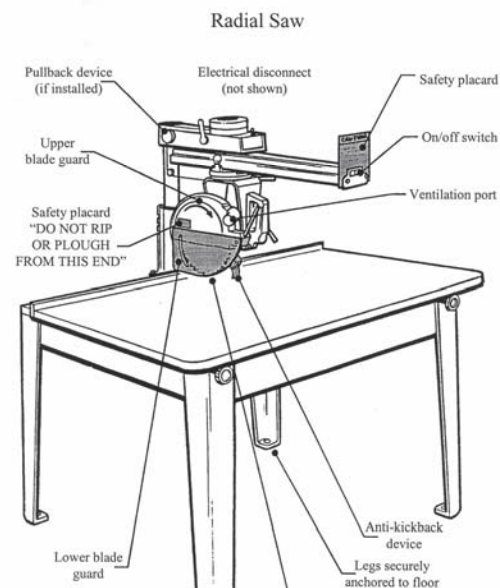

### Case Study

A worker operating a radial arm saw lost his thumb and fingers on his left hand when he pulled the saw across with his right hand while his left hand was in the blade path.

**References:** 29 CFR 1910.213; ANSI O1.1

Onsite Safety & Health Consultation Program  
1-800/972-4216

# Radial Saw



## Guarding:

- ❖ Provide guards for the radial saw. 1910.213(h)(1). When in the rest position, there should be no access to the saw blade. Guards consist of two parts:
  - ❖ An upper guard to enclose the non-cutting part of the saw blade to protect the operator from flying splinters, broken saw teeth and sawdust. Extend the guard at least as far down as the saw spindle.
  - ❖ Side guards for the lower exposed portion of the blade that can rise and open on contact with the workpiece. This device automatically adjust itself to the thickness of the stock and remain in contact with stock being cut to give maximum protection possible for the operation being performed. 1910.213(h)(1)
- ❖ Make sure that all power transmission is completely enclosed to prevent contract. This includes rotating components such as flywheels, gears, sheaves, shafts, belts and pulleys, chain and sprocket, meshing gears. 1910.213(a)(9) and 1910.219
- ❖ Provide an adjustable stop to prevent the forward travel of the blade beyond the position necessary to complete the cut in repetitive operations. A limit chain can be provided to prevent the saw blade from sliding beyond the edge of the table; or the table could be extended to eliminate over-run. 1910.213(h)(3)
- ❖ Provide an operating automatic return device so that the saw returns to its safe rest position behind the rear fence when the saw is released. If counterweights are used and they are exposed to contact, ensure that they are enclosed by a guard to the floor or by a safety device that will hold twice the weight of the counterweight. Consider rising the front of the machine (if you have a manually operated saw) slightly higher than the rear, so that the cutting head will not roll or move out on the arm and away from the column due to gravity or vibration. 1910.213(h)(4)  
  
Provide warning signs as a reminder to employees to operate the machine properly: A permanent label, color coded in standard caution yellow, affixed to the cutting head and clearly visible from the normal crosscut operating position reading as follows: WARNING: To Avoid Injury, Return Carriage to the Full Rear Position after Each Crosscut Type of Operation
- ❖ When the saw is used for ripping, place anti-kickback devices on both sides of the saw blade on the out feed side, to oppose the thrust or tendency of the blade to pick up material or to throw it back toward the operator. 1910.213(h)(2)
- ❖ Ensure that ripping and ploughing is against the direction in which the saw turns. Conspicuously mark the direction of the saw rotation on the hood. 1910.213(h)(5)
- ❖ Place a permanent label not less than 1-1/2 inches by 3/4 inch to the rear of the guard at approximately the level of the arbor, reading as follows: ``Danger: Do Not Rip or Plough From This End". 1910.213(h)(5)

## Safer Work Practices

- ❑ Train the operators of woodworking equipment before they are permitted to operate the equipment. They should receive instructions in the hazards of the machine and the safe method of its operation, and the proper personal protective equipment.
- ❑ Provide combs (featherboards) or suitable jigs for use when a standard guard cannot be used, as in dadoing, grooving, jointing, moulding, and rabbeting. 1910.213(s)(9)

## Radial Saw



- ❑ Provide and ensure that proper eye/face protection, hearing and respiratory protection is available and use when needed.
- ❑ Ensure that floors are in good condition and free of obstructions, that effective means to prevent slipping are provided, and a well illuminated work area is available.
- ❑ Only use saw blades rated at or above the speed of the saw arbour.
- ❑ Stand on the handle side when cross cutting. Pull the cutting head with the hand nearest the handle and maneuver the stock with the other hand.
- ❑ Make sure the hand holding the stock is never in line with the blade.
- ❑ When ripping, make sure that the overall length of the saw table (both infeed and outfeed) is twice the length of the longest pieces of lumber.
- ❑ When ripping, make sure that the stock is fed against the direction of the blade (from the side where the saw blade rotates upward toward the operator). The blade should extend slightly into the table. The motor head must be locked at the correct height and angle.
- ❑ Make measurements by placing the wood to be cut against the stop gauge. When measuring with a tape measure or ruler is necessary, turn off the saw until the measuring is complete.
- ❑ Do not cut "free hand". Use the back guide or fence, or other device to keep the workpiece from moving.
- ❑ Do not use cracked or dull blades.
- ❑ Do not leave a running saw unattended - leave only after the saw has been turned off and it has come to a complete stop.

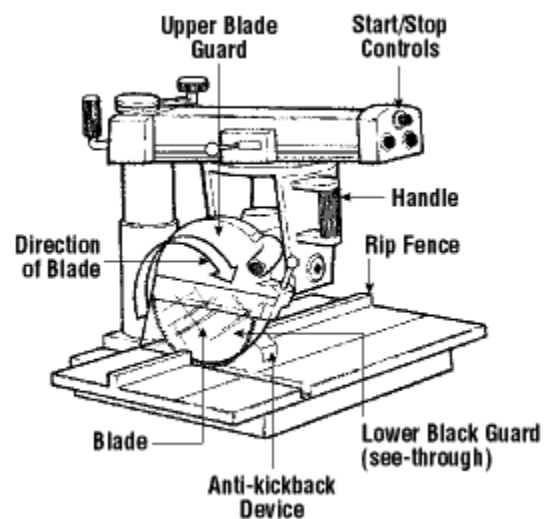

The number of accidents and the circumstances in which they occur show that most can be avoided by a knowledge of the risks and by adopting safety measures. The simple safety steps given below will help to prevent most accidents at grinding machines. You may find them useful as a safety check list.